



6W

INDUCTION MOTOR
 60mm LEAD WIRE TYPE

SIZE mm sq.	Type	Poles	Output (W)	Voltage (V)	Frequency (Hz)	Duty	Rated Load				Starting Torque		Capacitor (uF)
							Current (A)	Speed (rpm)	Torque (kg-cm) (N-m)		(kg-cm)	(N-m)	
60	S6I06GA S6I06GACE	4	6	1 ∅ 110	60	Cont.	0.20	1550	0.40	0.040	0.55	0.055	2.5
	S6I06GB S6I06GBCE	4	6	1 ∅ 220	60	Cont.	0.10	1550	0.40	0.040	0.55	0.055	0.7
	S6I06GC S6I06GCCCE	4	6	1 ∅ 100	50	Cont.	0.21	1200	0.50	0.050	0.45	0.045	2.5
					60		0.19	1500	0.42	0.042			
	S6I06GD S6I06GDCE	4	6	1 ∅ 200	50	Cont.	0.10	1200	0.50	0.050	0.45	0.045	0.7
					60			1500	0.42	0.042			
	S6I06GE S6I06GECE	4	6	1 ∅ 100	50	Cont.	0.18	1200	0.50	0.050	0.52	0.052	2.5
					60		0.19	1500	0.42	0.042			
					1 ∅ 115		60	0.19	1500	0.42			
	S6I06GX S6I06GXCE	4	6	1 ∅ 220	50	Cont.	0.08	1200	0.50	0.050	0.50	0.050	0.6
				1 ∅ 240			0.09		0.53	0.053			

- S6I06GE is UL approved (UL FILE No. E172722) impedance protected type.
- Please use appropriate capacitors according to the using voltage for S6I06GE type since the size of the capacitors differ to the different voltages and when not used properly, it may cause malfunction. Please inform required voltage when ordering or capacitor for 115V will be delivered.
- "CE" marked at the end of model name indicates that it is impedance protected type which has received CE (File NO. E9766002E01, Certificate Institute: TÜV Rhinland) S6I06GECE is available only for 115V specification.
- There is no marked the 'L' code for it is an exclusive use.

50Hz

GEAR RATIO	3 3.6 5 6 7.5 9 10 12.5 15 18 20 25 30 36 40 50 60 75 90 100 120 150 180 200 250																										
	MODEL	rpm	500	416	300	250	200	166	150	120	100	83	75	60	50	41	37	30	25	20	16	15	12	10	8	7.5	6
S6DA□B	kg-cm	1.3	1.5	2.1	2.6	3.2	3.9	4.3	5.4	6.4	7.7	7.7	9.7	11.6	13.9	15.5	17.5	21.0	26.2	30.0	30.0	30.0	30.0	30.0	30.0	30.0	30.0
	Nm	0.127	0.147	0.206	0.255	0.314	0.382	0.421	0.529	0.627	0.755	0.755	0.951	1.137	1.362	1.519	1.715	2.058	2.568	2.942	2.942	2.942	2.942	2.942	2.942	2.942	2.942

60Hz

GEAR RATIO	3 3.6 5 6 7.5 9 10 12.5 15 18 20 25 30 36 40 50 60 75 90 100 120 150 180 200 250																										
	MODEL	rpm	600	500	360	300	240	200	180	144	120	100	90	72	60	50	45	36	30	24	20	18	15	12	10	9	7.2
S6DA□B	kg-cm	1.0	1.3	1.7	2.1	2.6	3.1	3.5	4.4	5.2	6.3	6.3	7.8	9.4	11.3	12.6	14.2	17.0	21.3	25.5	28.4	30.0	30.0	30.0	30.0	30.0	30.0
	Nm	0.098	0.127	0.167	0.206	0.255	0.304	0.343	0.431	0.510	0.617	0.617	0.764	0.921	1.107	1.235	1.392	1.666	2.087	2.499	2.783	2.942	2.942	2.942	2.942	2.942	2.942

- The code in □ of gearhead model is for gear ratio.
- It is the permissible torque of the assembled motor and gearhead.
- The permissible torque of the assembled with motor and inter-decimal gearhead is 30kg · cm.
- ■ color indicates that the output shaft of the geared motor rotates in the same direction as the output shaft of the motor. Others indicate rotation in the opposite direction.
- Rotational speed based on synchronous speed (50Hz:1500rpm, 60Hz:1800rpm) divided by gear ratio. The actual rotation speed is less 2-20% than the displayed value according to the load.
- There is no marked the 'L' code for it is an exclusive use.

DIMENSIONS

▼ GEARED MOTOR

- ※ MOTOR MODEL : S6I06G□
- ※ HEAD MODEL : S6□A3□~S6□A250□

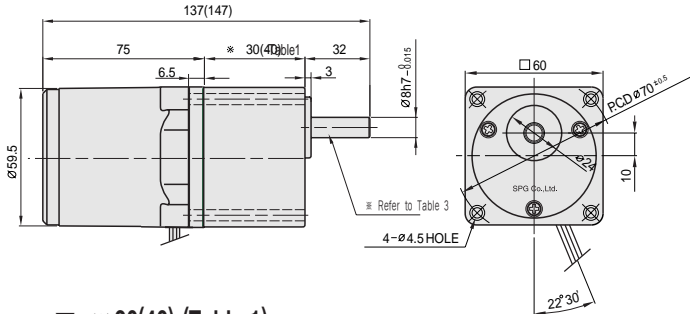

▼ ※ 30(40)-(Table 1)

GEAR RATIO	SIZE(mm)
S6□A3□~S6□A18□	30
S6□A20□~S6□A250□	40

▼ KEY SPEC

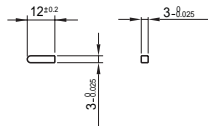

▼ INTER-DECIMAL GEARHEAD

- ※ MODEL : S6GX10B

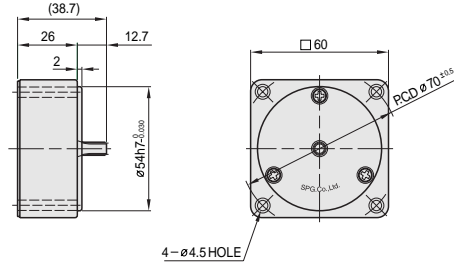

▼ WEIGHT-(Table 2)

PART	WEIGHT(Kg)	
MOTOR	0.70	
DECIMAL GEARHEAD	0.18	
GEAR HEAD	S6□A3□ ~S6□A18□	0.24
	S6□A20□ ~S6□A40□	0.30
	S6□A50□ ~S6□A250□	0.33

▼ SPEC for output shaft of gearhead-(Table 3) ▼ SPEC for output shaft of motor-(Table 4)

MODEL	TYPES OF OUTPUT SHAFT
STRAIGHT TYPE	
S6SA3□ ~S6SA250□	
D-CUT TYPE	
S6DA3□ ~S6DA250□	
KEY TYPE	
S6KA3□ ~S6KA250□	

MODEL	TYPES OF OUTPUT SHAFT
GEAR TYPE	
S6I06G□	
STRAIGHT TYPE	
S6I06S□	
D-CUT TYPE	
S6I06D□	

▼ MOTOR

- ※ MOTOR MODEL : S6I06□□

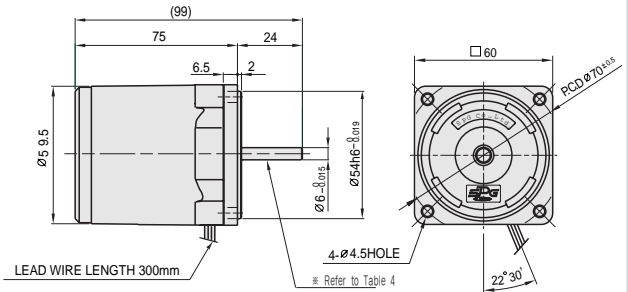

SCHEMATIC DIAGRAMS

The direction of motor rotation is as viewed from the front shaft end of the motor.

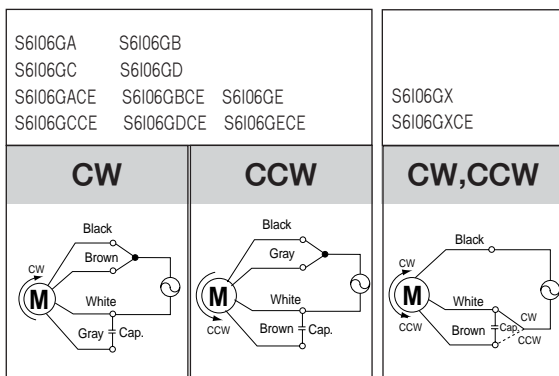

Change the direction of motor rotation only after the motor stops completely. If an attempt is made to change the direction of rotation while the motor is running, the motor may ignore the reversing command or change its direction of rotation after some delay.