

# DC Gear Motor

# 1.61.117.XXX

**Type 1.61.117.XXX**

V =	XXX	Characteristics*				max.	Terminal	Stages	Gear
		Rated current	Rated torque	Rated speed	No load speed	Torque*	resistance		ratio
		$I_N$ / A	$T_N$ / mNm	$n_N$ / rpm	$n_o$ / rpm	$T_{max}$ / mNm	$R_a$ / $\Omega$		

12 V	310	0.720	150	205	301	300	6.7	2	19.2
	311	0.660	200	145	203	300	6.7	2	28.4
	312	0.580	350	65	82	600	6.7	3	69.1
	313	0.490	400	47	55.5	600	6.7	3	102.0
	314	0.380	400	34	37.5	600	6.7	3	152.0
	315	0.360	450	21	22.5	800	6.7	4	249.0
	316	0.320	500	15	15	800	6.7	4	369.0
	317	0.290	600	10	10	800	6.7	4	546.0
	318	0.260	650	7	7	800	6.7	4	809.0

24 V	360	0.360	150	205	301	300	27	2	19.2
	361	0.330	200	145	203	300	27	2	28.4
	362	0.290	350	65	82	600	27	3	69.1
	363	0.240	400	47	55.5	600	27	3	102.0
	364	0.190	400	34	37.5	600	27	3	152.0
	365	0.180	450	21	22.5	800	27	4	249.0
	366	0.150	500	15	15	800	27	4	369.0
	367	0.140	600	10	10	800	27	4	546.0
	368	0.130	650	7	7	800	27	4	809.0

**Operational conditions**

Temperature range	T	°C	-10 - +70
Axial force	$F_A$	N	8
Radial force, 5 mm from mounting surface	$F_R$	N	15

\* at 25° C

Design	
Weight	95 g
Gear housing	Plastic
Commutator	Copper / 3-segments
RFI protection	VDR
Insulation class	Winding F, otherwise A
Protection class	IP30
Commutation	carbon brushes
Armature	straight slot
Magnet system	Permanent magnets, 2-pole
Bearings	2 sintered bronze bearings
Motor housing	Steel, corrosion protected
Motor end shields	brush end plastic drive end zinc die-cast
Planetary gear	Plastic gears
Axial play output shaft	0.05 - 0.6 mm

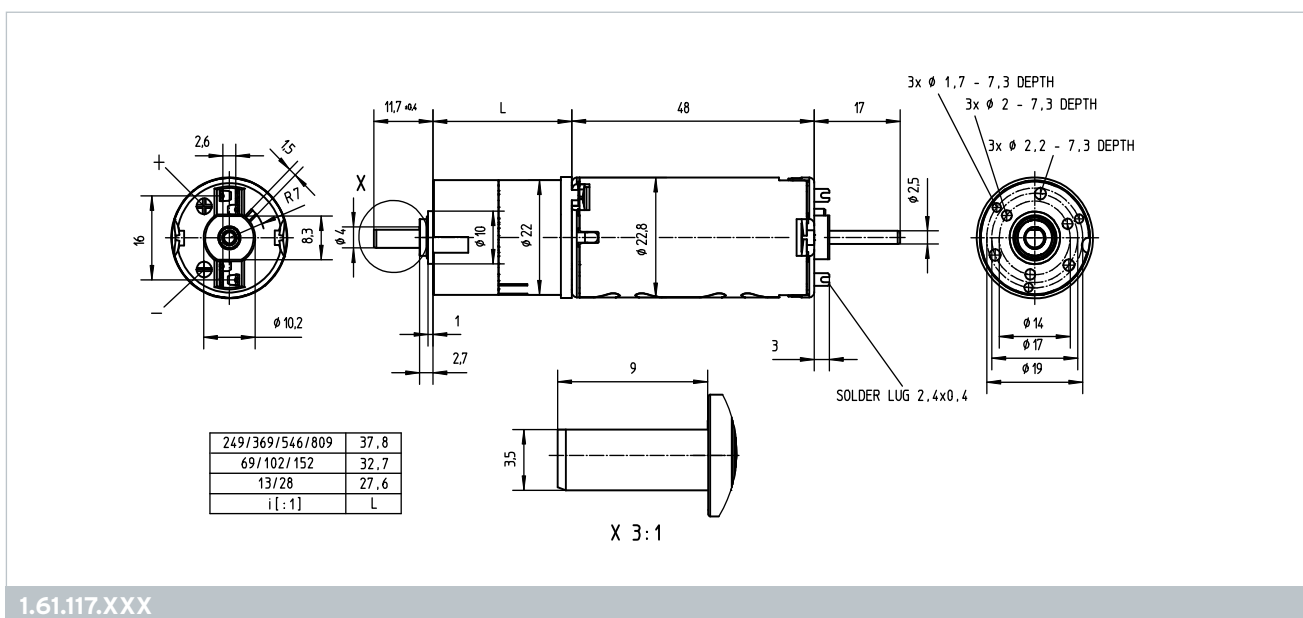

self tapping screw EJOT DELTA PT® K20 for  $\phi 1.7$  bore  
 K25 for  $\phi 2.0$  bore  
 K28 for  $\phi 2.2$  bore may be used

### Customized versions

The following modifications are available upon request:

- ▶ Encoder possible
- ▶ Internal chokes and/or capacitors
- ▶ Speed adjustment by winding change
- ▶ Addition of wire harnesses
- ▶ Modification of shaft length
- ▶ Modification of shaft configuration (flat, groove, etc.)
- ▶ Assembly of gears, pinions, etc.
- ▶ Assembly of adapters and mounting plates