

DC Gear Motor

1.61.077.XXX

Type 1.61.077.XXX

V =	XXX	Characteristics*				max.	Terminal	Stages	Gear
		Rated current	Rated torque	Rated speed	No load speed	Torque*	resistance		ratio
		I_N / A	T_N / mNm	n_N / rpm	n_o / rpm	T_{max} / mNm	R_a / Ω		
12 V	411	1.400	300	260	355	420	2.7	2	11.6
	412	1.400	550	140	190	770	2.7	2	21.4
	413	1.400	1000	75	105	1400	2.7	2	39.7
	414	0.850	1000	40	60	1400	4.8	3	72.0
	415	0.850	1800	23	33	2520	4.8	3	135.0
	416	0.550	2000	14	18	2800	4.8	3	250.0
24 V	421	0.700	300	260	355	420	10	2	11.6
	422	0.700	550	140	190	770	10	2	21.4
	423	0.700	1000	75	105	1400	10	2	39.7
	424	0.425	1000	40	60	1400	18	3	72.0
	425	0.425	1800	23	33	2520	18	3	135.0
	426	0.275	2000	14	18	2800	18	3	250.0

Operational conditions

Temperature range	T	°C	-10 - +70
Axial force	F_A	N	10
Radial force, 5 mm from mounting surface	F_R	N	30

* at 25° C

Design	
Weight	250 g
Gear housing	Plastic
Commutator	Copper / 7-segments
RFI protection	2 chokes
Insulation class	Winding H, otherwise A
Protection class	IP40
Commutation	carbon brushes
Armature	sintered, straight slot
Magnet system	Permanent magnets, 2-pole
Bearings	2 sintered bronze bearings
Motor housing	Steel, corrosion protected
Motor end shields	brush end plastic drive end zinc die-cast
Planetary gear	Plastic gears
Axial play output shaft	0.05 - 0.6 mm



1.61.077.XXX

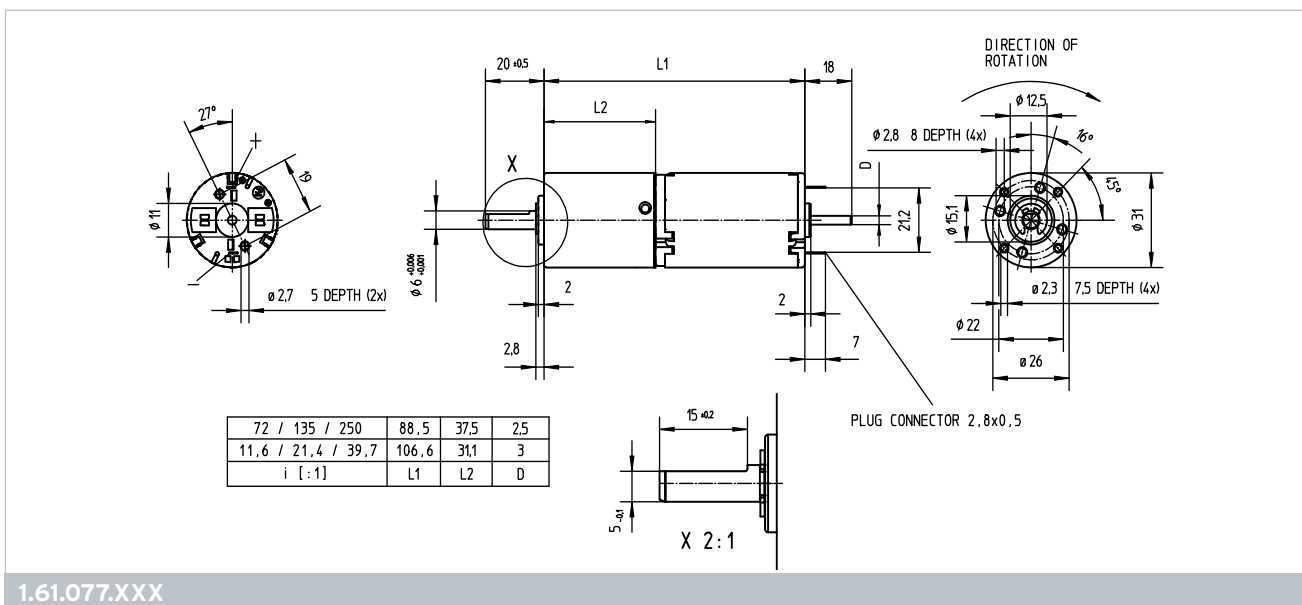

1.61.077.XXX

self tapping screw EJOT DELTA PT® K30 for $\phi 2.3$ bore may be used

Customized versions

The following modifications are available upon request:

- ▶ Encoder possible
- ▶ Internal chokes and/or capacitors
- ▶ Speed adjustment by winding change
- ▶ Addition of wire harnesses
- ▶ Modification of shaft length
- ▶ Modification of shaft configuration (flat, groove, etc.)
- ▶ Assembly of gears, pinions, etc.
- ▶ Assembly of adapters and mounting plates
- ▶ Gear ratios $i=3,4$ and $6,3$ on request