



25W

INDUCTION MOTOR
 80mm LEAD WIRE TYPE

SIZE mm sq.	Type	Poles	Output (W)	Voltage (V)	Frequency (Hz)	Duty	Rated Load				Starting Torque		Capacitor (uF)
							Current (A)	Speed (rpm)	Torque		(kg-cm)	(N-m)	
									(kg-cm)	(N-m)			
80	S8I25GA S8I25GA(TP) S8I25GACE	4	25	1 ∅ 110	60	Cont.	0.51	1600	1.60	0.160	1.80	0.180	6.0
	S8I25GB S8I25GB(TP) S8I25GBCE	4	25	1 ∅ 220	60	Cont.	0.23	1550	1.65	0.165	1.80	0.180	1.5
	S8I25GC S8I25GC(TP) S8I25GCCE	4	25	1 ∅ 100	50	Cont.	0.57	1250	2.00	0.200	1.45	0.145	6.0
		60	0.52	1550	1.65		0.165						
	S8I25GD S8I25GD(TP) S8I25GDCE	4	25	1 ∅ 200	50	Cont.	0.30	1250	2.00	0.200	1.45	0.145	1.5
		60	0.29	1500	1.70		0.170						
	S8I25GE S8I25GECE	4	25	1 ∅ 100	50	Cont.	0.54	1250	2.00	0.200	1.20	0.120	6.0
		60	0.55	1500	1.70		0.170						
		1 ∅ 115	60	0.59	1500		1.70	0.170	4.5				
	S8I25GX S8I25GXCE	4	25	1 ∅ 220	50	Cont.	0.23	1200	2.10	0.210	1.10	0.110	1.3
		1 ∅ 240	0.25	2.20	0.220		1.30		0.130				
	S8I25GU S8I25GUCE	4	25	3 ∅ 200	50	Cont.	0.26	1300	1.95	0.195	3.50	0.350	—
		60	0.24	1550	1.65		0.165	2.90	0.290				
	S8I25GT S8I25GTCE	4	25	3 ∅ 220	50	Cont.	0.28	1350	1.90	0.190	4.20	0.420	—
		60	0.24	1600	1.60		0.160	3.50	0.350				
	S8I25GS S8I25GSCE	4	25	3 ∅ 380	50	Cont.	0.14	1250	2.00	0.200	3.15	0.315	—
		60	0.12	1500	1.70		0.170	2.50	0.250				
		3 ∅ 400	50	0.14	1250	2.10	0.210	3.50	0.350				
	60	0.12	1500	1.80	0.180	2.75	0.275						
	3 ∅ 415	50	0.15	1300	1.95	0.195	3.75	0.375					
	60	0.13	1550	1.65	0.165	3.00	0.300						
	3 ∅ 440	50	0.15	1300	2.10	0.210	4.40	0.440					
	60	0.13	1550	1.80	0.180	3.40	0.340						

- S8I25GE is UL approved (UL FILE No. E172720) thermally protected type.
- Please use appropriate capacitors according to the using voltage for S8I25GE type since the size of the capacitors differ to the different voltages and when not used properly, it may cause malfunction. Please inform required voltage when ordering or capacitor for 115V will be delivered.
- "CE" marked at the end of model name indicates that it is thermally protected type which has received CE (File NO. E9766002E01, Certificate Institute: TÜV Rheinland) with built-in TPS8I25GECE is available only for 115V specification.
- "TP" marked at the end of the model name indicates that it is standard motor with Thermal Protector mounted. S8I25GE, S8I25GX, S8I25GS is thermally protected type with TP mounted.
- In case 3 phase 380V motor is controlled with inverter, please be careful to use considering.
- There is no marked the 'L' code for it is an exclusive use.

50Hz

MODEL	GEAR RATIO	Gear Ratio																							
		3	3.6	5	6	7.5	9	10	12.5	15	18	20	25	30	36	40	50	60	75	90	100	120	150	180	200
S8KA□B	rpm	500	416	300	250	200	166	150	120	100	83	75	60	50	41	37	30	25	20	16	15	12	10	8	7.5
	kg-cm	5.3	6.4	8.9	10.7	13.4	16.0	17.8	22.3	26.7	32.1	32.1	40.2	48.2	57.8	64.2	72.6	80.0	80.0	80.0	80.0	80.0	80.0	80.0	80.0
	Nm	0.519	0.627	0.872	1.049	1.313	1.568	1.744	2.185	2.617	3.146	3.146	3.940	4.724	5.664	6.292	7.115	7.840	7.840	7.840	7.840	7.840	7.840	7.840	7.840

60Hz

MODEL	GEAR RATIO	Gear Ratio																							
		3	3.6	5	6	7.5	9	10	12.5	15	18	20	25	30	36	40	50	60	75	90	100	120	150	180	200
S8KA□B	rpm	600	500	360	300	240	200	180	144	120	100	90	72	60	50	45	36	30	24	20	18	15	12	10	9
	kg-cm	4.4	5.2	7.3	8.7	10.9	13.1	14.6	18.2	21.9	26.2	26.3	32.9	39.4	47.3	52.6	59.4	71.3	80.0	80.0	80.0	80.0	80.0	80.0	80.0
	Nm	0.431	0.510	0.715	0.853	1.068	1.284	1.431	1.784	2.146	2.568	2.577	3.224	3.861	4.635	5.155	5.821	6.987	7.840	7.840	7.840	7.840	7.840	7.840	7.840

- The code in □ of gearhead model is for gear ratio.
- It is the permissible torque of the assembled motor and gearhead.
- The permissible torque of the assembled with motor and inter-decimal gearhead is 80kg · cm.
- ■ color indicates that the output shaft of the geared motor rotates in the same direction as the output shaft of the motor. Others indicate rotation in the opposite direction.
- Rotational speed based on synchronous speed (50Hz:1500rpm, 60Hz:1800rpm) divided by gear ratio. The actual rotation speed is less 2-20% than the displayed value according to the load.
- There is no marked the 'L' code for it is an exclusive use.

DIMENSIONS

GEARED MOTOR

※ MOTOR MODEL : S8I25G□
 ※ HEAD MODEL : S8□A3□~S8□A200□
 149(159.5)

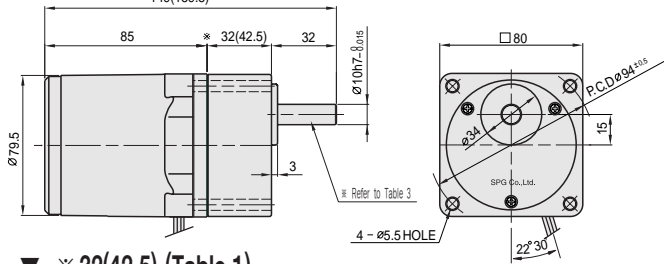

INTER-DECIMAL GEARHEAD

※ MODEL : S8GX10B

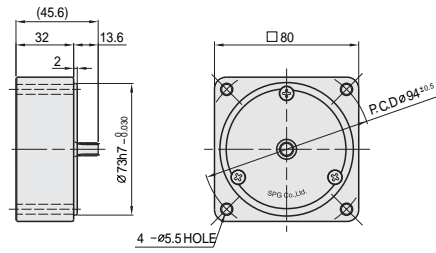

※ 32(42.5)-(Table 1)

GEAR RATIO	SIZE(mm)
S8□A3□~S8□A18□	32
S8□A20□~S8□A200□	42.5

WEIGHT-(Table 2)

PART	WEIGHT(Kg)	
MOTOR	1.46	
DECIMAL GEARHEAD	0.43	
GEAR HEAD	S8□A3□ ~S8□A18□	0.43
	S8□A20□ ~S8□A40□	0.57
	S8□A50□ ~S8□A200□	0.61

▼ SPEC for output shaft of gearhead-(Table 3)

MODEL	TYPES OF OUTPUT SHAFT
STRAIGHT TYPE	
S8SA3□ ~S8SA200□	
D-CUT TYPE	
S8DA3□ ~S8DA200□	
KEY TYPE	
S8KA3□ ~S8KA200□	

▼ SPEC for output shaft of motor-(Table 4)

MODEL	TYPES OF OUTPUT SHAFT
GEAR TYPE	
S8I25G□	
STRAIGHT TYPE	
S8I25S□	
D-CUT TYPE	
S8I25D□	
KEY TYPE	
S8I25K□	

MOTOR

※ MOTOR MODEL : S8I25□□

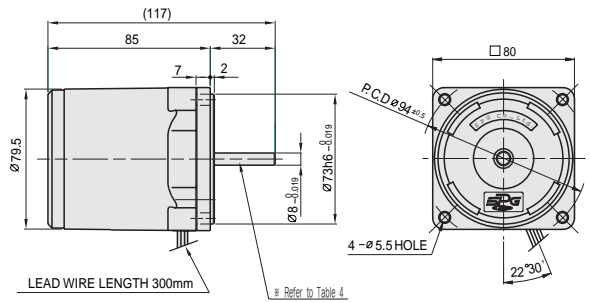

▼ KEY SPEC

GEARHEAD	MOTOR

SCHEMATIC DIAGRAMS

The direction of motor rotation is as viewed from the front shaft end of the motor.

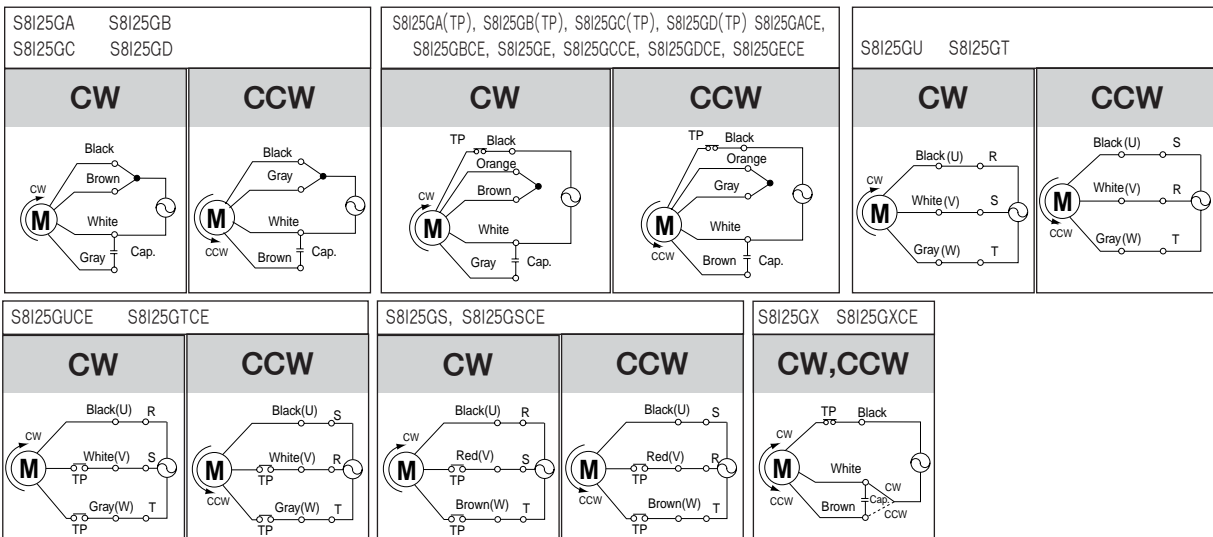

Change the direction of motor rotation only after the motor stops completely. If an attempt is made to change the direction of rotation while the motor is running, the motor may ignore the reversing command or change its direction of rotation after some delay.