



180W

INDUCTION MOTOR
 90mm LEAD WIRE TYPE

INDUCTION MOTORS

SIZE mm sq.	Type	Poles	Output (w)	Voltage (V)	Frequency (Hz)	Duty	Rated Load				Starting Torque		Capacitor (uF)
							Current (A)	Speed (rpm)	Torque (kg-cm) (N-m)		(kg-cm)	(N-m)	
90	S9I180GA S9I180GA(TP) S9I180GACE	4	180	1 ∅ 110	60	Cont.	2.60	1600	11.50	1.150	8.00	0.800	25.0
	S9I180GB S9I180GB(TP) S9I180GBCE	4	180	1 ∅ 220	60	Cont.	1.32	1600	11.50	1.150	8.00	0.800	6.5
	S9I180GC S9I180GC(TP) S9I180GCCE	4	180	1 ∅ 100	50	Cont.	3.20	1250	14.00	1.400	7.00	0.700	25.0
	60				2.90		1550	11.60	1.160				
	S9I180GD S9I180GD(TP) S9I180GDCE	4	180	1 ∅ 200	50	Cont.	1.60	1250	14.00	1.400	7.00	0.700	6.5
	60				1.45		1550	11.60	1.160				

- "CE" marked at the end of model name indicates that it is thermally protected type which has received CE (File NO. E9766002E01, Certificate Institute: TÜV Rhinland) with built-in TP.
- "TP" marked at the end of the model name indicates that it is standard motor with Thermal Protector mounted.
- There is not marked the 'H' type caused by exclusive use.

50Hz

GEAR RATIO		3	3.6	5	6	7.5	9	10	12.5	15	18	20	25	30	36	40	50	60	75	90	100	120	150	180	200
MODEL	rpm	500	416	300	250	200	166	150	120	100	83	75	60	50	41	37	30	25	20	16	15	12	10	8	7.5
	kg-cm	34.0	41.0	57.0	68.0	85.1	102	113	128	153	184	204	230	278	300	300	300	300	300	300	300	300	300	300	300
S9KH□B	N·m	3.336	4.021	5.590	6.672	8.341	10.01	11.12	12.55	15.01	18.04	20.02	22.56	27.26	29.42	29.42	29.42	29.42	29.42	29.42	29.42	29.42	29.42	29.42	29.42

60Hz

GEAR RATIO		3	3.6	5	6	7.5	9	10	12.5	15	18	20	25	30	36	40	50	60	75	90	100	120	150	180	200
MODEL	rpm	600	500	360	300	240	200	180	144	120	100	90	72	60	50	45	36	30	24	20	18	15	12	10	9
	kg-cm	28.1	34.0	47.0	57.0	71.0	84.2	94.0	105	126	152	168	189	227	273	300	300	300	300	300	300	300	300	300	300
S9KH□B	N·m	2.756	3.334	4.609	5.590	6.963	8.257	9.218	10.30	12.39	14.91	16.51	18.58	22.29	26.75	29.42	29.42	29.42	29.42	29.42	29.42	29.42	29.42	29.42	29.42

- The code in □ of gearhead model is for gear ratio.
- It is the permissible torque of the assembled motor and gearhead.
- ■ color indicates that the output shaft of the geared motor rotates in the same direction as the output shaft of the motor. Others indicate rotation in the opposite direction.
- Rotational speed based on synchronous speed (50Hz:1500rpm, 60Hz:1800rpm) divided by gear ratio. The actual rotation speed is less 2-20% than the displayed value according to the load.
- There is not marked the 'H' type caused by exclusive use.

DIMENSIONS

▼ GEARED MOTOR

※ MOTOR MODEL : S9I180G□
 ※ HEAD MODEL : S9□H3B-S9□H200B
 (284.8)

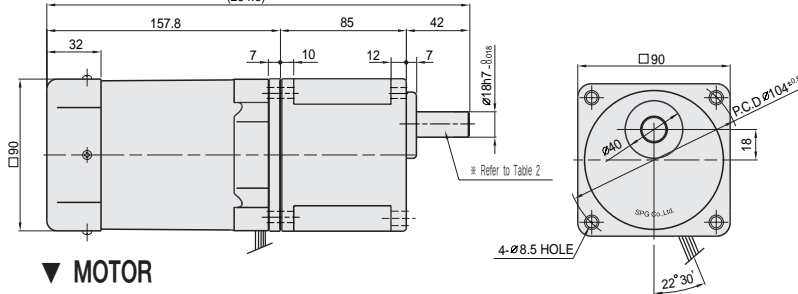

▼ MOTOR

※ MOTOR MODEL : S9I180□□
 (194.8)

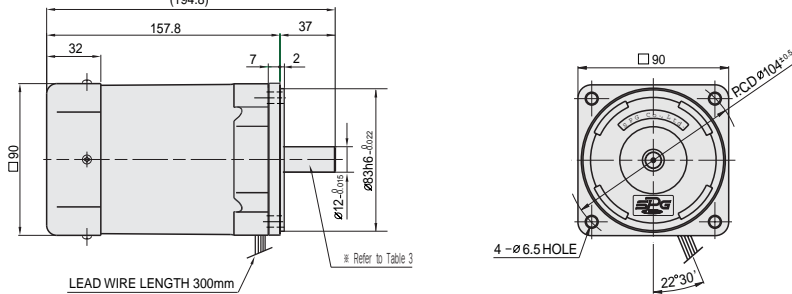

▼ WEIGHT-(Table 1)

PART		WEIGHT(Kg)
MOTOR		3.70
GEAR HEAD	S9□H3B ~S9□H10B	1.65
	S9□H12.5B ~S9□H20B	1.80
	S9□H25B ~S9□H60B	1.90
	S9□H75B ~S9□H200B	1.95

▼ SPEC for output shaft of gearhead-(Table 2) ▼ SPEC for output shaft of motor-(Table 3)

MODEL	TYPES OF OUTPUT SHAFT	MODEL	TYPES OF OUTPUT SHAFT
STRAIGHT TYPE		GEAR TYPE	
S9SH3B ~S9SH200B		S9I180G□	
D-CUT TYPE		STRAIGHT TYPE	
S9DH3B ~S9DH200B		S9I180S□	
KEY TYPE		D-CUT TYPE	
S9KH3B ~S9KH200B		S9I180D□	
▼ KEY SPEC		KEY TYPE	
GEARHEAD		MOTOR	
S9I180K□		S9I180K□	

SCHEMATIC DIAGRAMS

The direction of motor rotation is as viewed from the front shaft end of the motor.

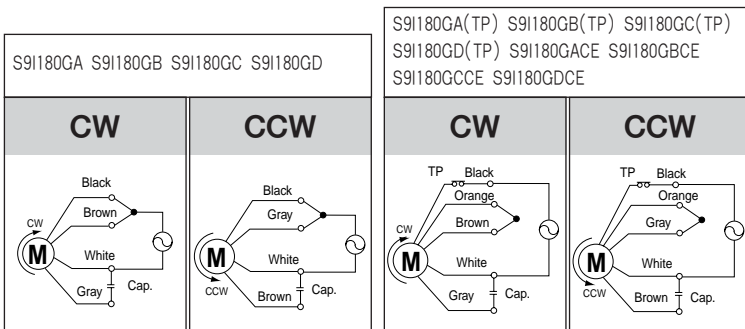

Change the direction of motor rotation only after the motor stops completely. If an attempt is made to change the direction of rotation while the motor is running, the motor may ignore the reversing command or change its direction of rotation after some delay.