



15W

INDUCTION MOTOR
 80mm LEAD WIRE TYPE

SIZE mm sq.	Type	Poles	Output (W)	Voltage (V)	Frequency (Hz)	Duty	Rated Load				Starting Torque		Capacitor (uF)
							Current (A)	Speed (rpm)	Torque (kg-cm) (N-m)		(kg-cm)	(N-m)	
80	S8I15GA S8I15GA(TP) S8I15GACE	4	15	1 ∅ 110	60	Cont.	0.43	1600	1.00	0.100	1.20	0.120	4.0
	S8I15GB S8I15GB(TP) S8I15GBCE	4	15	1 ∅ 220	60	Cont.	0.22	1600	1.00	0.100	1.20	0.120	1.0
	S8I15GC S8I15GC(TP) S8I15GCCE	4	15	1 ∅ 100	50 60	Cont.	0.51 0.43	1300 1550	1.20 1.00	0.120 0.100	0.95	0.095	4.0
	S8I15GD S8I15GD(TP) S8I15GDCE	4	15	1 ∅ 200	50 60	Cont.	0.25 0.22	1300 1550	1.20 1.00	0.120 0.100	0.95	0.095	1.0
	S8I15GE S8I15GECE	4	15	1 ∅ 100 1 ∅ 115	50 60	Cont.	0.51 0.42 0.46	1250 1550 1600	1.20 1.00 1.00	0.120 0.100 0.100	0.95	0.095	4.0 3.0
	S8I15GX S8I15GXCE	4	15	1 ∅ 220 1 ∅ 240	50	Cont.	0.16 0.17	1200	1.30 1.40	0.130 0.140	0.95 1.10	0.095 0.110	1.0

- S8I15GE is UL approved (UL FILE No. E172720) thermally protected type.
- Please use appropriate capacitors according to the using voltage for S8I15GE type since the size of the capacitors differ to the different voltages and when not used properly, it may cause malfunction. Please inform required voltage when ordering or capacitor for 115V will be delivered.
- "CE" marked at the end of model name indicates that it is thermally protected type which has received CE (File NO. E9766002E01, Certificate Institute: TÜV Rheinland) with built-in TP S8I15GECE is available only for 115V specification.
- "TP" marked at the end of the model name indicates that it is standard motor with Thermal Protector mounted. S8I15GE, S8I15GX is thermally protected type with TP mounted.
- There is no marked the 'L' code for it is an exclusive use.

50Hz

MODEL	GEAR RATIO	GEAR RATIO																							
		3	3.6	5	6	7.5	9	10	12.5	15	18	20	25	30	36	40	50	60	75	90	100	120	150	180	200
S8KA <input type="checkbox"/> B	rpm	500	416	300	250	200	166	150	120	100	83	75	60	50	41	37	30	25	20	16	15	12	10	8	7.5
	kg-cm	3.4	4.1	5.7	6.8	8.5	10.2	11.3	14.2	17.0	20.4	20.4	25.6	30.7	36.8	40.9	46.2	55.4	69.2	80	80	80	80	80	80
	N·m	0.333	0.402	0.559	0.666	0.833	1.000	1.107	1.392	1.666	1.999	1.999	2.509	3.009	3.606	4.008	4.530	5.433	6.786	7.840	7.840	7.840	7.840	7.840	7.840

60Hz

MODEL	GEAR RATIO	GEAR RATIO																							
		3	3.6	5	6	7.5	9	10	12.5	15	18	20	25	30	36	40	50	60	75	90	100	120	150	180	200
S8KA <input type="checkbox"/> B	rpm	600	500	360	300	240	200	180	144	120	100	90	72	60	50	45	36	30	24	20	18	15	12	10	9
	kg-cm	2.9	3.5	4.9	5.8	7.3	8.7	9.7	12.2	14.6	17.5	17.5	21.9	26.3	31.5	35.0	39.6	47.5	59.4	71.3	79.2	80	80	80	80
	N·m	0.284	0.343	0.481	0.568	0.715	0.853	0.951	1.196	1.432	1.715	1.715	2.146	2.577	3.087	3.430	3.883	4.658	5.825	6.992	7.767	7.840	7.840	7.840	7.840

- The code in of gearhead model is for gear ratio.
- It is the permissible torque of the assembled motor and gearhead.
- The permissible torque of the assembled with motor and inter-decimal gearhead is 80kg·cm.
- color indicates that the output shaft of the geared motor rotates in the same direction as the output shaft of the motor. Others indicate rotation in the opposite direction.
- Rotational speed based on synchronous speed (50Hz:1500rpm, 60Hz:1800rpm) divided by gear ratio. The actual rotation speed is less 2-20% than the displayed value according to the load.
- There is no marked the 'L' code for it is an exclusive use.

DIMENSIONS

▼ GEARED MOTOR

※ MOTOR MODEL : S8115G□
 ※ HEAD MODEL : S8□A3□~S8□A200□
 149(159.5)

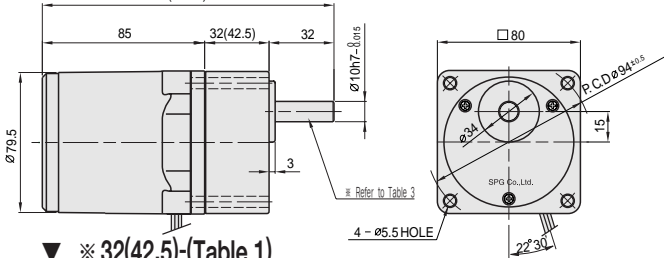

▼ ※ 32(42.5)-(Table 1)

GEAR RATIO	SIZE(mm)
S8□A3□~S8□A18□	32
S8□A20□~S8□A200□	42.5

WEIGHT-(Table 2) ▶

▼ INTER-DECIMAL GEARHEAD

※ MODEL : S8GX10B

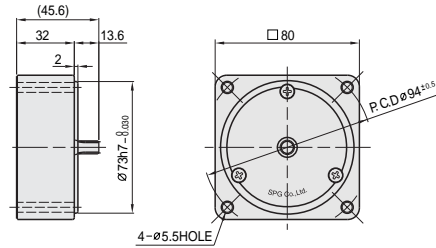

PART	WEIGHT(Kg)	
MOTOR	1.14	
DECIMAL GEARHEAD	0.43	
GEAR HEAD	S8□A3□ ~S8□A18□	0.43
	S8□A20□ ~S8□A40□	0.57
	S8□A50□ ~S8□A200□	0.61

▼ SPEC for output shaft of gearhead-(Table 3)

MODEL	TYPES OF OUTPUT SHAFT
STRAIGHT TYPE	
S8SA3□ ~S8SA200□	
D-CUT TYPE	
S8DA3□ ~S8DA200□	
KEY TYPE	
S8KA3□ ~S8KA200□	

▼ SPEC for output shaft of motor-(Table 4)

MODEL	TYPES OF OUTPUT SHAFT
GEAR TYPE	
S8115G□	
STRAIGHT TYPE	
S8115S□	
D-CUT TYPE	
S8115D□	
KEY TYPE	
S8115K□	

▼ KEY SPEC

GEARHEAD	MOTOR

▼ MOTOR

※ MOTOR MODEL : S8115□□

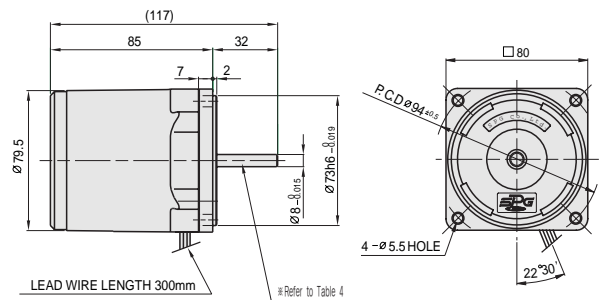

SCHEMATIC DIAGRAMS

The direction of motor rotation is as viewed from the front shaft end of the motor.

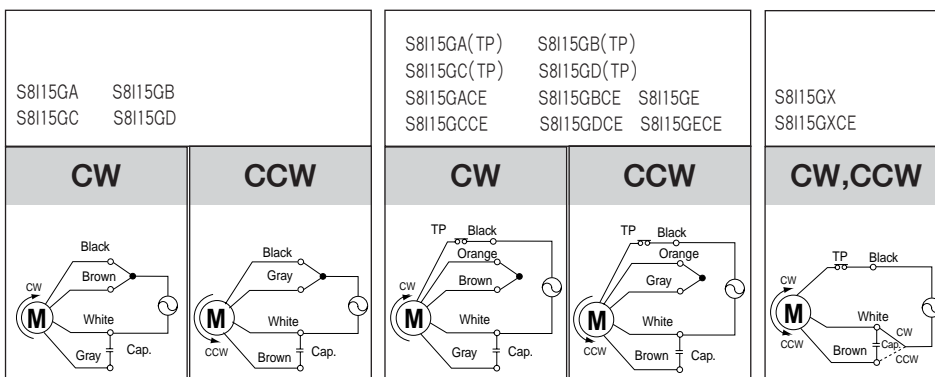

Change the direction of motor rotation only after the motor stops completely. If an attempt is made to change the direction of rotation while the motor is running, the motor may ignore the reversing command or change its direction of rotation after some delay.