



15W

ELECTROMAGNETIC BRAKE MOTOR
 70mm LEAD WIRE TYPE

SIZE mm sq.	Type	Poles	Output (W)	Voltage (V)	Frequency (Hz)	Duty	Rated Load				Starting Torque		Capacitor (uF)
							Current (A)	Speed (rpm)	Torque (kg-cm) (N-m)		(kg-cm)	(N-m)	
70	S7R15GA-E S7R15GA-E(TP) S7R15GA-ECE	4	15	1 ∅ 110	60	30min.	0.46	1550	1.00	0.100	1.25	0.125	6.0
	S7R15GB-E S7R15GB-E(TP) S7R15GB-ECE	4	15	1 ∅ 220	60	30min.	0.23	1600	1.00	0.100	1.20	0.120	1.5
	S7R15GC-E S7R15GC-E(TP) S7R15GC-ECE	4	15	1 ∅ 100	50	30min.	0.44	1200	1.25	0.125	1.00	0.100	6.0
	60												
	S7R15GD-E S7R15GD-E(TP) S7R15GD-ECE	4	15	1 ∅ 200	50	30min.	0.22	1250	1.25	0.125	1.00	0.100	1.5
	60												
	S7R15GE-E S7R15GE-ECE	4	15	1 ∅ 100	50	30min.	0.38	1250	1.25	0.125	1.00	0.100	6.0
	60												
	1 ∅ 115												
	S7R15GX-E S7R15GX-ECE	4	15	1 ∅ 220	50	30min.	0.17	1200	1.25	0.125	1.00	0.100	1.2
	1 ∅ 240												
	0.18												

- S7R15GE-E is UL approved(UL FILE NO. E172720) thermally protected type.
- Please use appropriate capacitors according to the using voltage for S7R15GE-E type since the size of the capacitors differ to the different voltages and when not used properly, it may cause malfunction. Please inform required voltage when ordering or capacitor for 115V will be delivered.
- "CE" marked at the end of model name indicates that it is thermally protected type which has received CE (File NO. E9766002E01, Certificate Institute: TÜV Rhinland)S7R15GE-ECE is available only for 115V specification.
- "TP" marked at the end of the model name indicates that it is standard motor with Thermal Protector mounted. S7R15GE-E, S7R15GX-E is thermally protected type with TP mounted.
- Above data is measured with brake removed from electromagnetic brake motor.
- There is no marked the 'L' code for it is an exclusive use.

50Hz

GEAR RATIO	3	3.6	5	6	7.5	9	10	12.5	15	18	20	25	30	36	40	50	60	75	90	100	120	150	180	200	
	MODEL	rpm	500	416	300	250	200	166	150	120	100	83	75	60	50	41	37	30	25	20	16	15	12	10	8
S7KA□B	kg-cm	3.2	3.9	5.4	6.5	8.1	9.7	10.8	13.5	16.2	19.4	19.4	24.2	29.1	34.9	38.8	43.6	50.0	50.0	50.0	50.0	50.0	50.0	50.0	50.0
	N·m	0.314	0.382	0.530	0.637	0.794	0.951	1.059	1.324	1.587	1.902	1.902	2.373	2.854	3.423	3.805	4.276	4.900	4.900	4.900	4.900	4.900	4.900	4.900	4.900

60Hz

GEAR RATIO	3	3.6	5	6	7.5	9	10	12.5	15	18	20	25	30	36	40	50	60	75	90	100	120	150	180	200	
	MODEL	rpm	600	500	360	300	240	200	180	144	120	100	90	72	60	50	45	36	30	24	20	18	15	12	10
S7KA□B	kg-cm	3.0	3.6	5.1	6.1	7.6	9.1	10.1	12.7	15.2	18.2	18.2	22.8	27.3	32.8	36.5	41.0	49.2	50.0	50.0	50.0	50.0	50.0	50.0	50.0
	N·m	0.294	0.353	0.500	0.598	0.745	0.892	0.990	1.245	1.491	1.785	1.785	2.236	2.677	3.217	3.579	4.021	4.825	4.900	4.900	4.900	4.900	4.900	4.900	4.900

- The code in □ of gearhead model is for gear ratio.
- It is the permissible torque of the assembled motor and gearhead.
- The permissible torque of the assembled with motor and inter-decimal gearhead is 50kg · cm.
- ■ color indicates that the output shaft of the geared motor rotates in the same direction as the output shaft of the motor. Others indicate rotation in the opposite direction.
- Rotational speed based on synchronous speed (50Hz:1500rpm, 60Hz:1800rpm) divided by gear ratio. The actual rotation speed is less 2-20% than the displayed value according to the load.
- There is no marked the 'L' code for it is an exclusive use.

DIMENSIONS

▼ GEARED MOTOR

* MOTOR MODEL : S7R15G□-E
 * HEAD MODEL : S7□A3□~S7□A200□

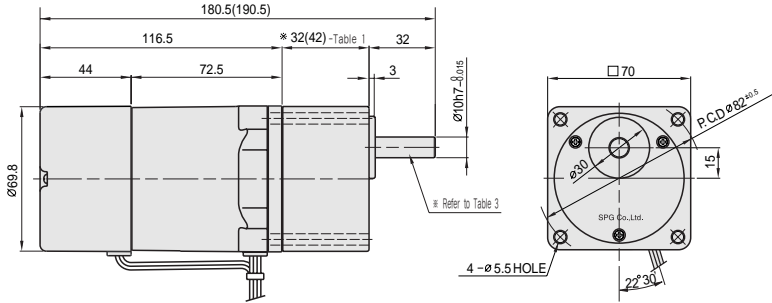

▼ * 32(42)-(Table 1)

GEAR RATIO	SIZE(mm)
S7□A3□~S7□A18□	32
S7□A20□~S7□A200□	42

▼ KEY SPEC

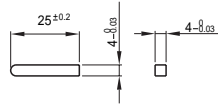

▼ INTER-DECIMAL GEAR HEAD

* MODEL : S7GX10B

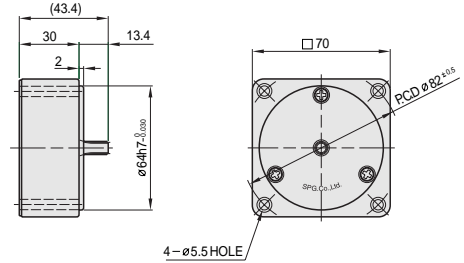

▼ WEIGHT-(Table 2)

PART	WEIGHT(kg)	
MOTOR	1.04	
DECIMAL GEARHEAD	0.32	
GEAR HEAD	S7□A3□ ~S7□A18□	0.38
	S7□A20□ ~S7□A40□	0.47
	S7□A50□ ~S7□A200□	0.52

▼ SPEC for output shaft of gearhead-(Table 3)

MODEL	TYPES OF OUTPUT SHAFT
STRAIGHT TYPE	
S7SA3□ ~S7SA200□	
D-CUT TYPE	
S7DA3□ ~S7DA200□	
KEY TYPE	
S7KA3□ ~S7KA200□	

▼ SPEC for output shaft of motor-(Table 4)

MODEL	TYPES OF OUTPUT SHAFT
GEAR TYPE	
S7R15G□-E	
STRAIGHT TYPE	
S7R15S□-E	
D-CUT TYPE	
S7R15D□-E	

▼ MOTOR

* MOTOR MODEL : S7R15□□-E

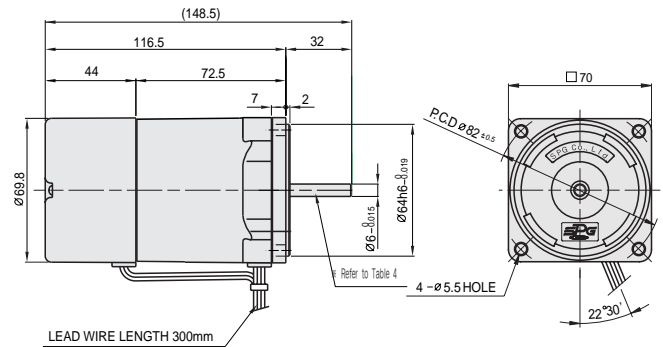

SCHEMATIC DIAGRAMS

The direction of motor rotation is as viewed from the front shaft end of the motor.

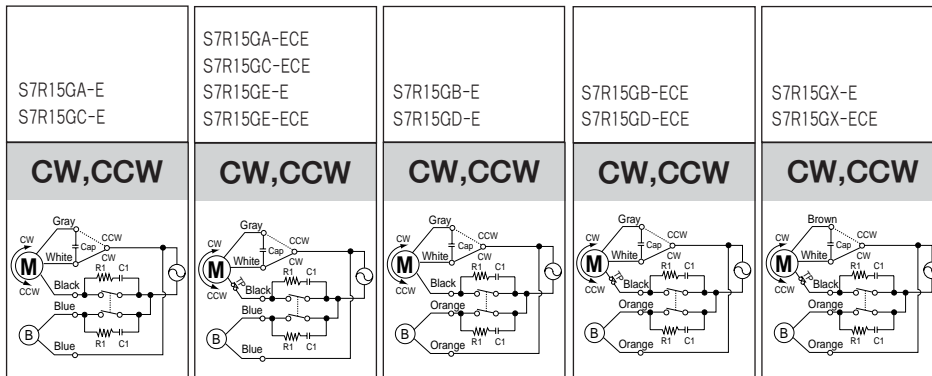

R₁ = 10~200 Ω (Min.1/4W)

C₁ = 0.1~0.33μF(AC125V or AC250V)