



6W

REVERSIBLE SPEED CONTROL MOTOR
 60mm LEAD WIRE TYPE

SPECIFICATION OF SOCKET SR TYPE SPEED CONTROL MOTORS

SIZE mm sq.	Motor Type	Controller Type	Poles	Output (W)	Voltage (V)	Freq. (Hz)	Duty	Speed Range (rpm)	Permissible Torque				Starting Torque		Cap. (μ F)
									at 1200rpm		at 90rpm		(kg-cm)	(N-m)	
60	S6R06GA-S12 S6R06GA-S12CE	SRA01 SRA01CE	4	6	1 ϕ 110	60	30min.	90-1700	0.65	0.065	0.40	0.040	0.52	0.052	3.0
	S6R06GB-S12 S6R06GB-S12CE	SRB01 SRB01CE	4	6	1 ϕ 220	60	30min.	90-1700	0.60	0.060	0.40	0.040	0.52	0.052	0.8
	S6R06GC-S12 S6R06GC-S12CE	SRC01 SRC01CE	4	6	1 ϕ 100	50 60	30min.	90-1400 90-1700	0.55	0.055	0.35	0.035	0.45	0.045	3.0
	S6R06GD-S12 S6R06GD-S12CE	SRD01 SRD01CE	4	6	1 ϕ 200	50 60	30min.	90-1400 90-1700	0.55	0.055	0.35	0.035	0.45	0.045	0.8
	S6R06GX-S12 S6R06GX-S12CE	SRX01 SRX01CE	4	6	1 ϕ 220 1 ϕ 240	50	30min.	90-1400	0.45 0.50	0.045 0.050	0.32 0.32	0.032 0.032	0.40 0.47	0.040 0.047	0.7

- "CE" marked at the end of motor model name indicates that it is thermally protected type which has received CE (File NO. E9766002E01, Certificate Institute: TÜV Rhinland).
- SR type controller model with "CE" appeared at the end of motor model name indicates that the product acquired CE MARK certification. (File NO. E9766429E01, Certificate Institute: TÜV Rhinland)
- There is no marked 'L' code for it is an exclusive use.

SPECIFICATION OF SOCKET SS TYPE SPEED CONTROL MOTORS

SIZE mm sq.	Motor Type	Controller Type	Poles	Output (W)	Voltage (V)	Freq. (Hz)	Duty	Speed Range (rpm)	Permissible Torque				Starting Torque		Cap. (μ F)
									at 1200rpm		at 90rpm		(kg-cm)	(N-m)	
60	S6R06GA-S24 S6R06GA-S24CE	SSA01-SRSS SSA03-SRSS	4	6	1 ϕ 110	60	30min.	90-1700	0.65	0.065	0.40	0.040	0.52	0.052	3.0
	S6R06GB-S24 S6R06GB-S24CE	SSB01-SRSS SSB03-SRSS	4	6	1 ϕ 220	60	30min.	90-1700	0.60	0.060	0.40	0.040	0.52	0.052	0.8
	S6R06GC-S24 S6R06GC-S24CE	SSC01-SRSS SSC03-SRSS	4	6	1 ϕ 100	50 60	30min.	90-1400 90-1700	0.55	0.055	0.35	0.035	0.45	0.045	3.0
	S6R06GD-S24 S6R06GD-S24CE	SSD01-SRSS SSD03-SRSS	4	6	1 ϕ 200	50 60	30min.	90-1400 90-1700	0.55	0.055	0.35	0.035	0.45	0.045	0.8
	S6R06GX-S24 S6R06GX-S24CE	SSX01-SRSS SSX03-SRSS	4	6	1 ϕ 220 1 ϕ 240	50	30min.	90-1400	0.45 0.50	0.045 0.050	0.32 0.32	0.032 0.032	0.40 0.47	0.040 0.047	0.7

- "CE" marked at the end of motor model name indicates that it is thermally protected type which has received CE (File NO. E9766002E01, Certificate Institute: TÜV Rhinland).
- There is no marked 'L' code for it is an exclusive use.

50Hz

GEAR RATIO		3	3.6	5	6	7.5	9	10	12.5	15	18	20	25	30	36	40	50	60	75	90	100	120	150	180	200	250
MODEL	rpm	500	416	300	250	200	166	150	120	100	83	75	60	50	41	37	30	25	20	16	15	12	10	8	7.5	6
	kg·cm	1.3	1.5	2.1	2.6	3.2	3.9	4.3	5.4	6.4	7.7	7.7	9.7	11.6	13.9	15.5	17.5	21.0	26.2	30.0	30.0	30.0	30.0	30.0	30.0	30.0
S6DA□B	N·m	0.127	0.147	0.206	0.255	0.314	0.382	0.421	0.529	0.627	0.755	0.755	0.951	1.137	1.362	1.519	1.715	2.058	2.568	2.942	2.942	2.942	2.942	2.942	2.942	

60Hz

GEAR RATIO		3	3.6	5	6	7.5	9	10	12.5	15	18	20	25	30	36	40	50	60	75	90	100	120	150	180	200	250
MODEL	rpm	600	500	360	300	240	200	180	144	120	100	90	72	60	50	45	36	30	24	20	18	15	12	10	9	7.2
	kg·cm	1.0	1.3	1.7	2.1	2.6	3.1	3.5	4.4	5.2	6.3	6.3	7.8	9.4	11.3	12.6	14.2	17.0	21.3	25.5	28.4	30.0	30.0	30.0	30.0	30.0
S6DA□B	N·m	0.098	0.127	0.167	0.206	0.255	0.304	0.343	0.431	0.510	0.617	0.617	0.764	0.921	1.107	1.235	1.392	1.666	2.087	2.499	2.783	2.942	2.942	2.942	2.942	2.942

- The code in □ of gearhead model is for gear ratio.
- It is the permissible torque of the assembled motor and gearhead.
- The permissible torque of the assembled with motor and inter-decimal gearhead is 30kg·cm.
- ■ color indicates that the output shaft of the geared motor rotates in the same direction as the output shaft of the motor. Others indicate rotation in the opposite direction.
- Rotational speed based on synchronous speed (50Hz:1500rpm, 60Hz:1800rpm) divided by gear ratio. The actual rotation speed is less 2-20% than the displayed value according to the load.
- There is no marked 'L' code for it is an exclusive use.

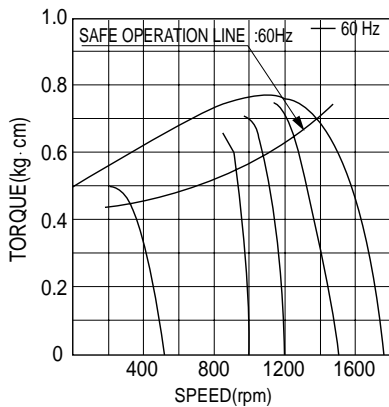

- ▲ S6R06GA-S12 S6R06GA-S24
- S6R06GA-S12CE S6R06GA-S24CE
- S6R06GB-S12 S6R06GB-S24
- S6R06GB-S12CE S6R06GB-S24

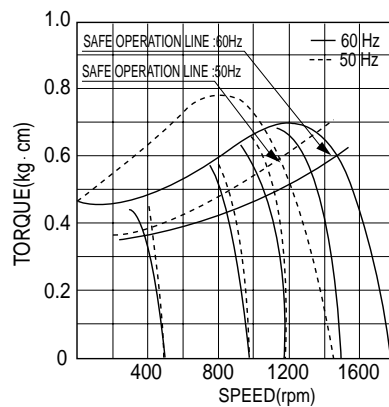

- ▲ S6R06GC-S12 S6R06GC-S24
- S6R06GC-S12CE S6R06GC-S24CE
- S6R06GD-S12 S6R06GD-S24
- S6R06GD-S12CE S6R06GD-S24CE

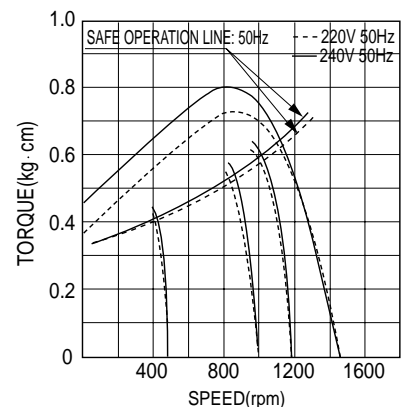

- ▲ S6R06GX-S12 S6R06GX-S24
- S6R06GX-S12CE S6R06GX-S24CE

DIMENSIONS

▼ GEARED MOTOR

※ MOTOR MODEL : S6R06G□-S12, S6R06G□-S24
 ※ HEAD MODEL □ : S6□A3□~S6□A250□

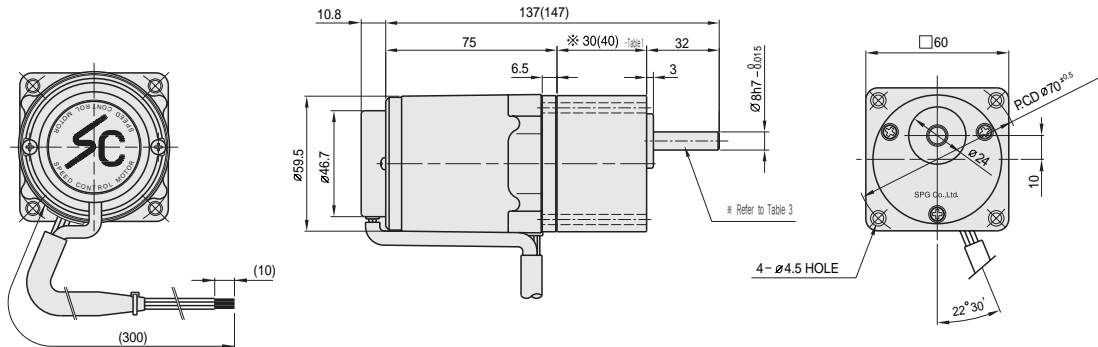

▼ MOTOR

※ MOTOR MODEL : S6R06□□-S12
 S6R06□□-S24

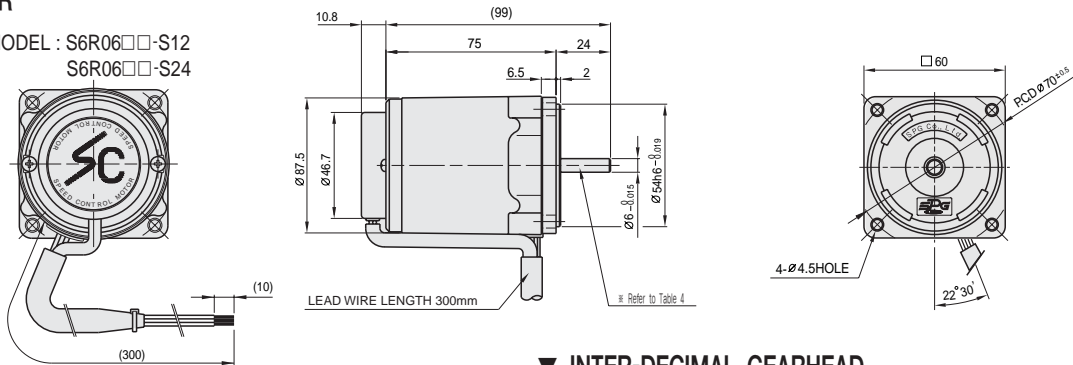

▼ INTER-DECIMAL GEARHEAD

※ MODEL : S6GX10B

▼ ※ 30(40)-(Table 1)

GEAR RATIO	SIZE(mm)
S6□A3□~S6□A18□	30
S6□A20□~S6□A250□	40

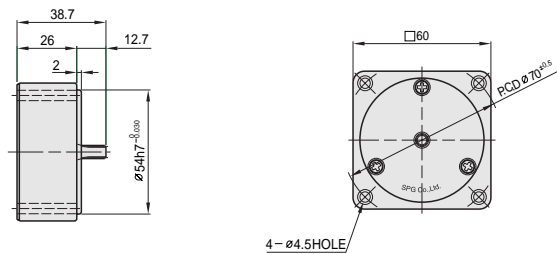

▼ SPEC for output shaft of gearhead-(Table 3)

MODEL	TYPES OF OUTPUT SHAFT
STRAIGHT TYPE	
S6SA3□ ~S6SA250□	
D-CUT TYPE	
S6DA3□ ~S6DA250□	
KEY TYPE	
S6KA3□ ~S6KA250□	

▼ SPEC for output shaft of motor-(Table 4)

MODEL	TYPES OF OUTPUT SHAFT
GEAR TYPE	
S6R06G□-S12 S6R06G□-S24	
STRAIGHT TYPE	
S6R06S□-S12 S6R06S□-S24	
D-CUT TYPE	
S6R06D□-S12 S6R06D□-S24	

▼ KEY SPEC

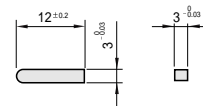

▼ WEIGHT-(Table 2)

PART	WEIGHT(kg)	
MOTOR	0.76	
DECIMAL GEARHEAD	0.18	
GEAR HEAD	S6□A3□ ~S6□A18B□	0.24
	S6□A20□ ~S6□A40□	0.30
	S6□A50□ ~S6□A250□	0.33