



# 60W

INDUCTION SPEED CONTROL MOTOR  
 90mm LEAD WIRE TYPE

## ■ SPECIFICATION OF SOCKET SR TYPE SPEED CONTROL MOTORS

SIZE mm sq.	Motor Type	Controller Type	Poles	Output (W)	Voltage (V)	Freq. (Hz)	Duty	Speed Range (rpm)	Permissible Torque				Starting Torque		Cap. (μF)
									at 1200rpm		at 90rpm		(kg-cm)	(N-m)	
90	S9I60GA()-S12 S9I60GA()-S12(TP) S9I60GA()-S12CE	SRA02 SRA02CE	4	60	1 ∅ 110	60	Cont.	90-1700	5.50	0.550	2.00	0.200	5.00	0.500	20.0
	S9I60GB()-S12 S9I60GB()-S12(TP) S9I60GB()-S12CE	SRB02 SRB02CE	4	60	1 ∅ 220	60	Cont.	90-1700	5.50	0.550	2.00	0.200	5.00	0.500	5.0
	S9I60GC()-S12 S9I60GC()-S12(TP) S9I60GC()-S12CE	SRC02 SRC02CE	4	60	1 ∅ 100	50 60	Cont.	90-1400 90-1700	5.50 5.00	0.550 0.500	1.20	0.120	4.00	0.400	20.0
	S9I60GD()-S12 S9I60GD()-S12(TP) S9I60GD()-S12CE	SRD02 SRD02CE	4	60	1 ∅ 200	50 60	Cont.	90-1400 90-1700	5.50 5.00	0.550 0.500	1.20	0.120	4.00	0.400	5.0
	S9I60GX()-S12 S9I60GX()-S12CE	SRX02 SRX02CE	4	60	1 ∅ 220 1 ∅ 240	50	Cont.	90-1400	5.20 5.80	0.520 0.580	0.90 0.090	0.090 0.090	3.10 3.60	0.310 0.360	3.5

- "CE" marked at the end of motor model name indicates that it is thermally protected type which has received CE (File NO. E9766002E01, Certificate Institute: TÜV Rhinland).
- SR type controller model with "CE" appeared at the end of motor model name indicates that the product acquired CE MARK certification. (File NO. E9766429E01, Certificate Institute: TÜV Rhinland).
- "TP" marked at the end of the motor model name indicates that it is standard motor with Thermal Protector mounted. S9I60GX()-S12, S9I60GX()-S12CE is thermally protected type with TP mounted.
- ( ) is for marking 'L' type or 'H'. 'L' should be used with gearhead 'L' and 'H' should be used with gearhead 'H'.

## ■ SPECIFICATION OF SOCKET SS TYPE SPEED CONTROL MOTORS

SIZE mm sq.	Motor Type	Controller Type	Poles	Output (W)	Voltage (V)	Freq. (Hz)	Duty	Speed Range (rpm)	Permissible Torque				Starting Torque		Cap. (μF)
									at 1200rpm		at 90rpm		(kg-cm)	(N-m)	
90	S9I60GA()-S24 S9I60GA()-S24(TP) S9I60GA()-S24CE	SSA03-SRSS	4	60	1 ∅ 110	60	Cont.	90-1700	5.50	0.550	2.00	0.200	5.00	0.500	20.0
	S9I60GB()-S24 S9I60GB()-S24(TP) S9I60GB()-S24CE	SSB03-SRSS	4	60	1 ∅ 220	60	Cont.	90-1700	5.50	0.550	2.00	0.200	5.00	0.500	5.0
	S9I60GC()-S24 S9I60GC()-S24(TP) S9I60GC()-S24CE	SSC03-SRSS	4	60	1 ∅ 100	50 60	Cont.	90-1400 90-1700	5.50 5.00	0.550 0.500	1.20	0.120	4.00	0.400	20.0
	S9I60GD()-S24 S9I60GD()-S24(TP) S9I60GD()-S24CE	SSD03-SRSS	4	60	1 ∅ 200	50 60	Cont.	90-1400 90-1700	5.50 5.00	0.550 0.500	1.20	0.120	4.00	0.400	5.0
	S9I60GX()-S24 S9I60GX()-S24CE	SSX03-SRSS	4	60	1 ∅ 220 1 ∅ 240	50	Cont.	90-1400	5.20 5.80	0.520 0.580	0.90 0.090	0.090 0.090	3.10 3.60	0.310 0.360	3.5

- "CE" marked at the end of motor model name indicates that it is thermally protected type which has received CE (File NO. E9766002E01, Certificate Institute: TÜV Rhinland).
- "TP" marked at the end of the motor model name indicates that it is standard motor with Thermal Protector mounted. S9I60GX()-S24, S9I60GX()-S24CE is thermally protected type with TP mounted.
- ( ) is for marking 'L' type or 'H'. 'L' should be used with gearhead 'L' and 'H' should be used with gearhead 'H'.

## 50Hz

GEAR RATIO		3	3.6	5	6	7.5	9	10	12.5	15	18	20	25	30	36	40	50	60	75	90	100	120	150	180	200
MODEL	rpm	500	416	300	250	200	166	150	120	100	83	75	60	50	41	37	30	25	20	16	15	12	10	8	7.5
S9KC□B( )	kg·cm	12.2	14.6	20.3	24.3	30.4	36.5	40.5	45.6	54.8	65.7	73.0	82.5	99.0	119	132	165	198	200	200	200	200	200	200	200
S9KC□B( )-S	N·m	1.196	1.431	1.989	2.381	2.989	3.577	3.969	4.469	5.370	6.439	7.154	8.085	9.702	11.66	12.94	16.17	19.40	19.60	19.60	19.60	19.60	19.60	19.60	19.60

## 60Hz

GEAR RATIO		3	3.6	5	6	7.5	9	10	12.5	15	18	20	25	30	36	40	50	60	75	90	100	120	150	180	200
MODEL	rpm	600	500	360	300	240	200	180	144	120	100	90	72	60	50	45	36	30	24	20	18	15	12	10	9
S9KC□B( )	kg·cm	9.72	11.7	16.2	19.4	24.3	29.2	32.4	36.5	43.8	52.6	58.4	66.0	79.2	95.0	106	132	158	177	200	200	200	200	200	200
S9KC□B( )-S	N·m	0.953	1.147	1.588	1.901	2.381	2.862	3.175	3.577	4.292	5.155	5.723	6.468	7.762	9.310	10.39	12.94	15.48	17.35	19.60	19.60	19.60	19.60	19.60	19.60

- The code in □ of gearhead model is for gear ratio.
- It is the permissible torque of the assembled motor and gearhead.
- The permissible torque of the assembled with motor and inter-decimal gearhead is 200kg·cm.
- ■ color indicates that the output shaft of the geared motor rotates in the same direction as the output shaft of the motor. Others indicate rotation in the opposite direction.
- Rotational speed based on synchronous speed (50Hz:1500rpm, 60Hz:1800rpm) divided by gear ratio. The actual rotation speed is less 2-20% than the displayed value according to the load.
- ( ) is for marking 'L' type or 'H'. 'L' should be used with motor 'L' and 'H' should be used with motor 'H'.

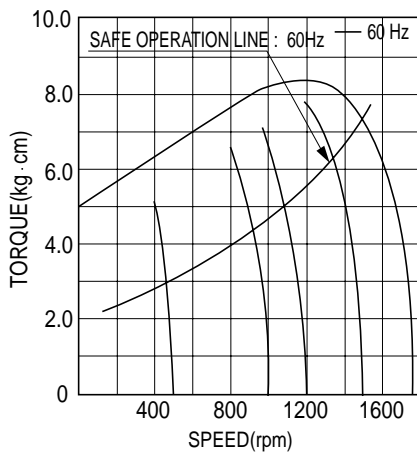

- ▲ S9I60GA()-S12      S9I60GA()-S24
- S9I60GA()-S12(TP)      S9I60GA()-S24(TP)
- S9I60GA()-S12CE      S9I60GA()-S24CE
- S9I60GB()-S12      S9I60GB()-S24
- S9I60GB()-S12(TP)      S9I60GB()-S24(TP)
- S9I60GB()-S12CE      S9I60GB()-S24

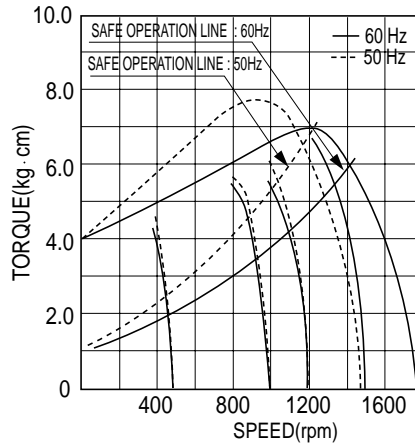

- ▲ S9I60GC()-S12      S9I60GC()-S24
- S9I60GC()-S12(TP)      S9I60GC()-S24(TP)
- S9I60GC()-S12CE      S9I60GC()-S24CE
- S9I60GD()-S12      S9I60GD()-S24
- S9I60GD()-S12(TP)      S9I60GD()-S24(TP)
- S9I60GD()-S12CE      S9I60GD()-S24

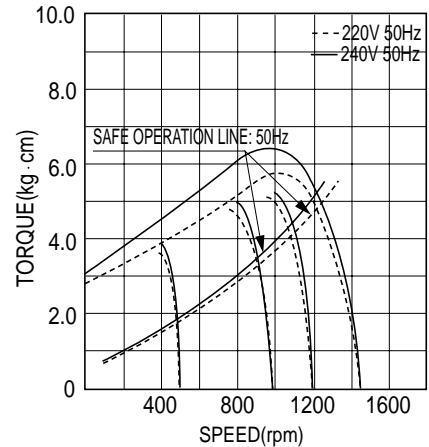

- ▲ S9I60GX()-S12      S9I60GX()-S24
- S9I60GX()-S12CE      S9I60GX()-S24CE

# DIMENSIONS

## ▼ GEARED MOTOR

- \* MOTOR MODEL : S9I60G□□-S12  
S9I60G□□-S24
- \* HEAD MODEL : S9□C3B□-S  
~S9□C200B□-S

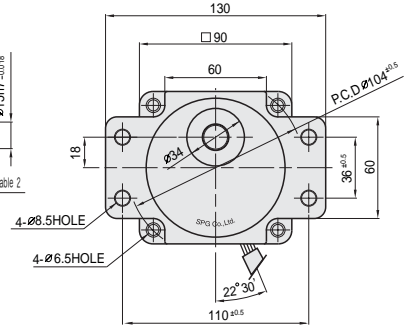
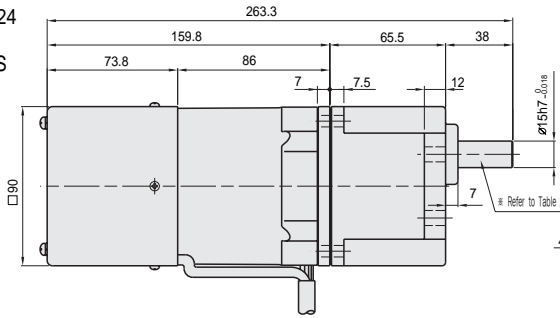
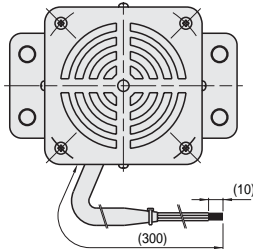

## ▼ MOTOR

- \* HEAD MODEL : S9□C3B□  
~S9□C200B□

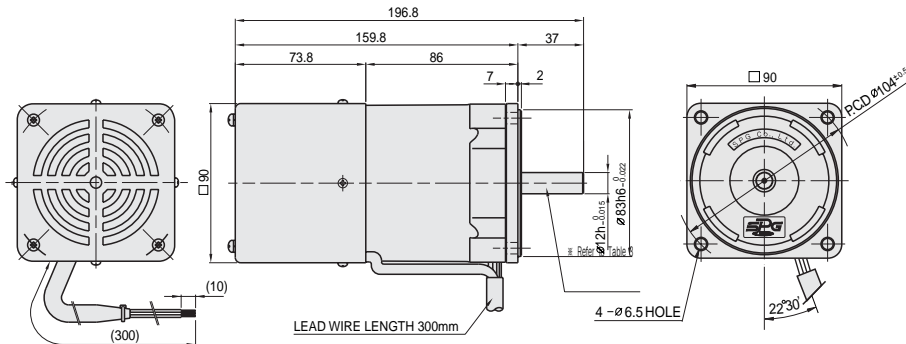
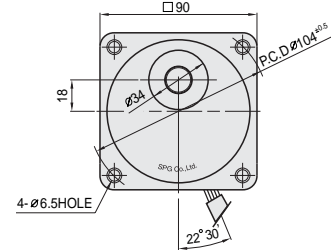
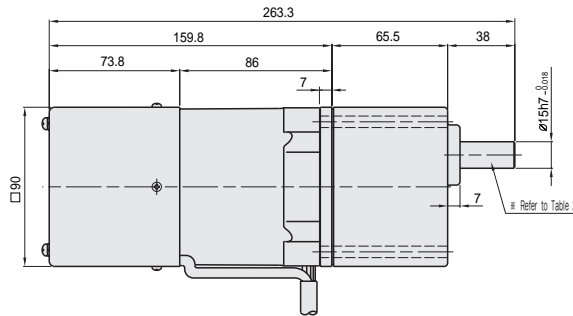
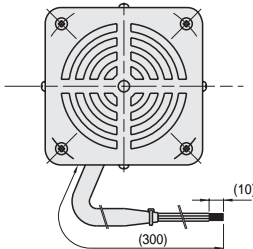

## ▼ INTER-DECIMAL GEARHEAD

- \* MODEL : S9GX10B(H,L)-S

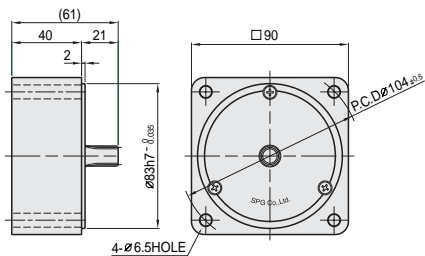

## ▼ KEY SPEC

GEARHEAD	MOTOR

## ▼ SPEC for output shaft of gearhead-(Table 2)

MODEL	TYPES OF OUTPUT SHAFT
STRAIGHT TYPE	
S9SC3B□ ~S9SC200B□	
D-CUT TYPE	
S9DC3B□ ~S9DC200B□	
KEY TYPE	
S9KC3B□ ~S9KC200B□	

## ▼ WEIGHT-(Table 1)

PART	WEIGHT(kg)	
MOTOR	2.93	
DECIMAL GEARHEAD	0.65	
GEAR HEAD	S9□C3B□ ~S9□C10B□	1.21
	S9□C12.5B□ ~S9□C20B□	1.30
	S9□C25B□ ~S9□C60B□	1.40
	S9□C75B□ ~S9□C200B□	1.45

## ▼ SPEC for output shaft of gearhead-(Table 3)

MODEL	TYPE OF OUTPUT SHAFT
GEAR TYPE	
S9I60G□-S12 S9I60G□-S24	
STRAIGHT TYPE	
S9I60S□-S12 S9I60S□-S24	
D-CUT TYPE	
S9I60D□-S12 S9I60D□-S24	
KEY TYPE	
S9I60K□-S12 S9I60K□-S24	

# DIMENSIONS

## ▼ GEARED MOTOR

- \* MOTOR MODEL : S9I60G□□-S12, S9I60G□H
- \* HEAD MODEL : S9□D3B-S9□D200B

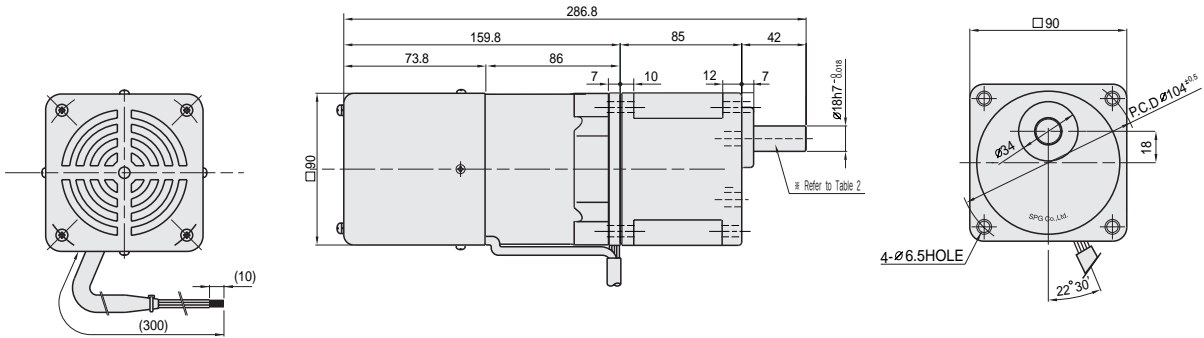

## ▼ KEY SPEC



## ▼ WEIGHT-(Table 1)

PART		WEIGHT(kg)
MOTOR		2.93
GEAR HEAD	S9□D3B ~S9□D10B	1.65
	S9□D12.5B ~S9□D20B	1.80
	S9□D25B ~S9□D60B	1.90
	S9□D75B ~S9□D200B	1.95

## ▼ SPEC for output shaft of gearhead-(Table 2)

MODEL	TYPES OF OUTPUT SHAFT
STRAIGHT TYPE	
S9SD3B ~S9SD200B	
D-CUT TYPE	
S9DD3B ~S9DD200B	
KEY TYPE	
S9KD3B ~S9KD200B	

SPEED CONTROLLER CONTROL MOTORS

## 50Hz

GEAR RATIO		3	3.6	5	6	7.5	9	10	12.5	15	18	20	25	30	36	40	50	60	75	90	100	120	150	180	200
MODEL	rpm	500	416	300	250	200	166	150	120	100	83	75	60	50	41	37	30	25	20	16	15	12	10	8	7.5
	kg·cm	18.2	21.9	30.4	36.5	45.6	54.7	60.8	68.4	82.1	98.6	110	124	149	178	198	248	297	300	300	300	300	300	300	300
S9KD□B	N·m	1.784	2.146	2.979	3.577	4.469	5.361	5.958	6.703	8.046	9.663	10.78	12.15	14.60	17.44	19.40	24.32	29.13	29.42	29.42	29.42	29.42	29.42	29.42	29.42

## 60Hz

GEAR RATIO		3	3.6	5	6	7.5	9	10	12.5	15	18	20	25	30	36	40	50	60	75	90	100	120	150	180	200
MODEL	rpm	600	500	360	300	240	200	180	144	120	100	90	72	60	50	45	36	30	24	20	18	15	12	10	9
	kg·cm	14.6	17.5	24.3	29.2	36.5	43.7	48.6	54.8	65.7	78.8	87.6	99.0	119	143	158	198	238	266	300	300	300	300	300	300
S9KD□B	N·m	1.431	1.715	2.381	2.862	3.577	4.675	4.763	5.370	6.439	7.722	8.585	9.702	11.66	14.01	15.48	19.40	23.34	26.09	29.42	29.42	29.42	29.42	29.42	29.42

- The code in □ of gearhead model is for gear ratio.
- It is the permissible torque of the assembled motor and gearhead.
- The permissible torque of the assembled with motor and inter-decimal gearhead is 300kg·cm.
- ■ color indicates that the output shaft of the geared motor rotates in the same direction as the output shaft of the motor. Others indicate rotation in the opposite direction.
- Rotational speed based on synchronous speed (50Hz:1500rpm, 60Hz:1800rpm) divided by gear ratio. The actual rotation speed is less 2-20% than the displayed value according to the load.
- There is not marked the 'h' type caused by exclusive use. Please use 'h' type motor.