



15W

INDUCTION SPEED CONTROL MOTOR
 70mm LEAD WIRE TYPE

■ SPECIFICATION OF SOCKET SR TYPE SPEED CONTROL MOTORS

SIZE mm sq.	Motor Type	Controller Type	Poles	Output (W)	Voltage (V)	Freq. (Hz)	Duty	Speed Range (rpm)	Permissible Torque				Starting Torque		Cap. (μ F)		
									at 1200rpm		at 90rpm		(kg-cm)	(N-m)		(kg-cm)	(N-m)
									(kg-cm)	(N-m)	(kg-cm)	(N-m)					
70	S7I15GA-S12 S7I15GA-S12(TP) S7I15GA-S12CE	SRA02 SRA02CE	4	15	1 ϕ 110	60	Cont.	90-1700	1.15	0.115	0.60	0.060	0.90	0.090	5.0		
	S7I15GB-S12 S7I15GB-S12(TP) S7I15GB-S12CE	SRB02 SRB02CE	4	15	1 ϕ 220	60	Cont.	90-1700	1.15	0.115	0.60	0.060	0.90	0.090	1.2		
	S7I15GC-S12 S7I15GC-S12(TP) S7I15GC-S12CE	SRC02 SRC02CE	4	15	1 ϕ 100	50 60	Cont.	90-1400 90-1700	1.10 1.00	0.110 0.100	0.40	0.040	0.75	0.075	5.0		
	S7I15GD-S12 S7I15GD-S12(TP) S7I15GD-S12CE	SRD02 SRD02CE	4	15	1 ϕ 200	50 60	Cont.	90-1400 90-1700	1.10 1.00	0.110 0.100	0.40	0.040	0.75	0.075	1.2		
	S7I15GX-S12 S7I15GX-S12CE	SRX02 SRX02CE	4	15	1 ϕ 220 1 ϕ 240	50	Cont.	90-1400	1.05 1.25	0.105 0.125	0.50 0.60	0.050 0.060	0.70 0.85	0.070 0.085	0.9		

- "CE" marked at the end of motor model name indicates that it is thermally protected type which has received CE (File NO. E9766002E01, Certificate Institute: TÜV Rheinland).
- SR type controller model with "CE" appeared at the end of motor model name indicates that the product acquired CE MARK certification. (File NO. E9766429E01, Certificate Institute: TÜV Rheinland)
- "TP" marked at the end of the motor model name indicates that it is standard motor with Thermal Protector mounted. S7I15GX-S12, S7I15GX-S12CE is thermally protected type with TP mounted.
- There is no marked 'L' code for it is an exclusive use.

■ SPECIFICATION OF SOCKET SS TYPE SPEED CONTROL MOTORS

SIZE mm sq.	Motor Type	Controller Type	Poles	Output (W)	Voltage (V)	Freq. (Hz)	Duty	Speed Range (rpm)	Permissible Torque				Starting Torque		Cap. (μ F)		
									at 1200rpm		at 90rpm		(kg-cm)	(N-m)		(kg-cm)	(N-m)
									(kg-cm)	(N-m)	(kg-cm)	(N-m)					
70	S7I15GA-S24 S7I15GA-S24(TP) S7I15GA-S24CE	SSA02-SRSS SSA03-SRSS	4	15	1 ϕ 110	60	Cont.	90-1700	1.15	0.115	0.60	0.060	0.90	0.090	5.0		
	S7I15GB-S24 S7I15GB-S24(TP) S7I15GB-S24CE	SSB02-SRSS SSB03-SRSS	4	15	1 ϕ 220	60	Cont.	90-1700	1.15	0.115	0.60	0.060	0.90	0.090	1.2		
	S7I15GC-S24 S7I15GC-S24(TP) S7I15GC-S24CE	SSC02-SRSS SSC03-SRSS	4	15	1 ϕ 100	50 60	Cont.	90-1400 90-1700	1.10 1.00	0.110 0.100	0.40	0.040	0.75	0.075	5.0		
	S7I15GD-S24 S7I15GD-S24(TP) S7I15GD-S24CE	SSD02-SRSS SSD03-SRSS	4	15	1 ϕ 200	50 60	Cont.	90-1400 90-1700	1.10 1.00	0.110 0.100	0.40	0.040	0.75	0.075	1.2		
	S7I15GX-S24 S7I15GX-S24CE	SSX02-SRSS SSX03-SRSS	4	15	1 ϕ 220 1 ϕ 240	50	Cont.	90-1400	1.05 1.25	0.105 0.125	0.50 0.60	0.050 0.060	0.70 0.85	0.070 0.085	0.9		

- "CE" marked at the end of motor model name indicates that it is thermally protected type which has received CE (File NO. E9766002E01, Certificate Institute: TÜV Rheinland).
- "TP" marked at the end of the motor model name indicates that it is standard motor with Thermal Protector mounted. S7I15GX-S24, S7I15GX-S24CE is thermally protected type with TP mounted.
- There is no marked 'L' code for it is an exclusive use.

50Hz

GEAR RATIO		3	3.6	5	6	7.5	9	10	12.5	15	18	20	25	30	36	40	50	60	75	90	100	120	150	180	200
MODEL	rpm	500	416	300	250	200	166	150	120	100	83	75	60	50	41	37	30	25	20	16	15	12	10	8	7.5
	kg·cm	3.2	3.9	5.4	6.5	8.1	9.7	10.8	13.5	16.2	19.4	19.4	24.2	29.1	34.9	38.8	43.6	50.0	50.0	50.0	50.0	50.0	50.0	50.0	50.0
S7KA□B	N·m	0.314	0.382	0.530	0.637	0.794	0.951	1.059	1.324	1.587	1.902	1.902	2.373	2.854	3.423	3.805	4.276	4.900	4.900	4.900	4.900	4.900	4.900	4.900	

60Hz

GEAR RATIO		3	3.6	5	6	7.5	9	10	12.5	15	18	20	25	30	36	40	50	60	75	90	100	120	150	180	200
MODEL	rpm	600	500	360	300	240	200	180	144	120	100	90	72	60	50	45	36	30	24	20	18	15	12	10	9
	kg·cm	3.0	3.6	5.1	6.1	7.6	9.1	10.1	12.7	15.2	18.2	18.2	22.8	27.3	32.8	36.5	41.0	49.2	50.0	50.0	50.0	50.0	50.0	50.0	50.0
S7KA□B	N·m	0.294	0.353	0.500	0.598	0.745	0.892	0.990	1.245	1.491	1.785	1.785	2.236	2.677	3.217	3.579	4.021	4.825	4.900	4.900	4.900	4.900	4.900	4.900	4.900

- The code in □ of gearhead model is for gear ratio.
- It is the permissible torque of the assembled motor and gearhead.
- The permissible torque of the assembled with motor and inter-decimal gearhead is 50kg·cm.
- ■ color indicates that the output shaft of the geared motor rotates in the same direction as the output shaft of the motor. Others indicate rotation in the opposite direction.
- Rotational speed based on synchronous speed (50Hz:1500rpm, 60Hz:1800rpm) divided by gear ratio. The actual rotation speed is less 2-20% than the displayed value according to the load.
- There is no marked 'L' code for it is an exclusive use.

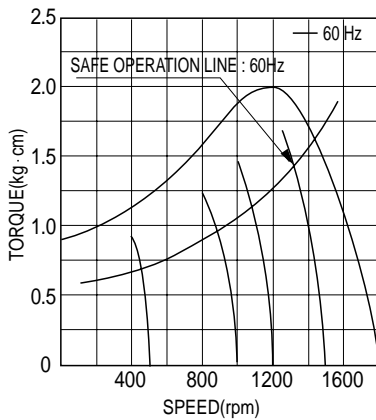

- ▲ S7I15GA-S12 S7I15GA-S24
- S7I15GA-S12(TP) S7I15GA-S24(TP)
- S7I15GA-S12CE S7I15GA-S24CE
- S7I15GB-S12 S7I15GB-S24
- S7I15GB-S12(TP) S7I15GB-S24(TP)
- S7I15GB-S12CE S7I15GB-S24

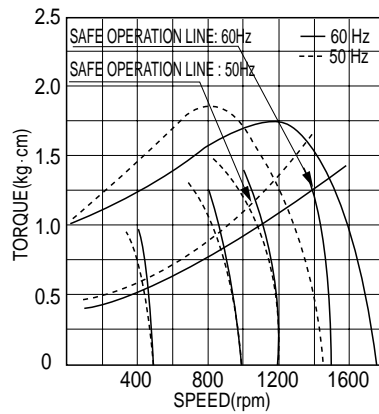

- ▲ S7I15GC-S12 S7I15GC-S24
- S7I15GC-S12(TP) S7I15GC-S24(TP)
- S7I15GC-S12CE S7I15GC-S24CE
- S7I15GD-S12 S7I15GD-S24
- S7I15GD-S12(TP) S7I15GD-S24(TP)
- S7I15GD-S12CE S7I15GD-S24

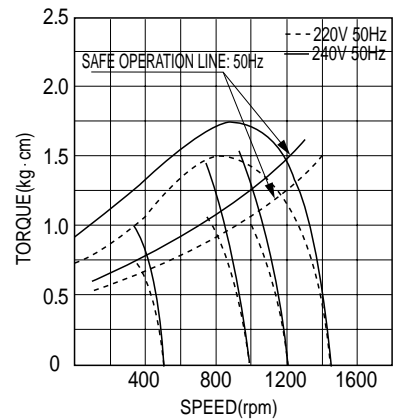

- ▲ S7I15GX-S12 S7I15GX-S24
- S7I15GX-S12CE S7I15GX-S24CE

DIMENSIONS

▼ GEARED MOTOR

- ※ MOTOR MODEL : S7115G□-S12, S7115G□-S24
- ※ HEAD MODEL : S7□A3□~S7□A200□

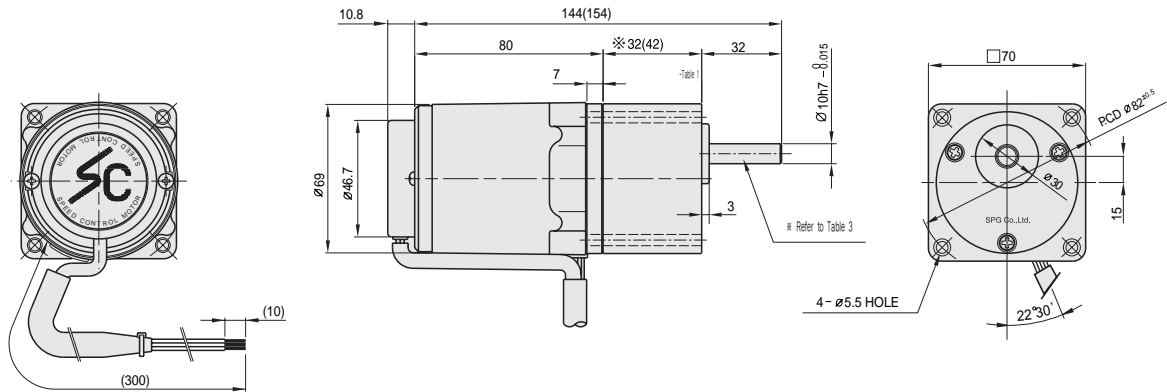

▼ MOTOR

- ※ MOTOR MODEL : S7115□□-S12, S7115□□-S24

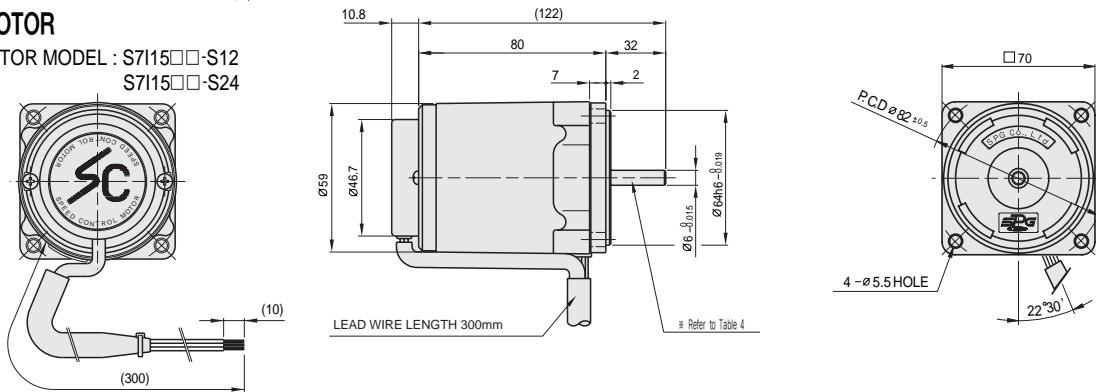

▼ ※ 32(42)-(Table 1)

GEAR RATIO	SIZE(mm)
S7□A3□~S7□A18□	32
S7□A20□~S7□A200□	42

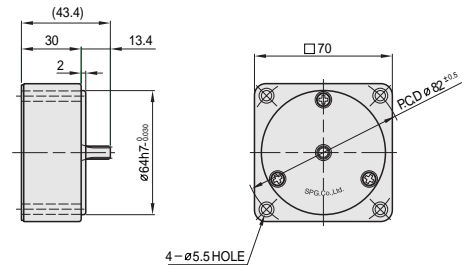

▼ SPEC for output shaft of gearhead-(Table 3)

MODEL	TYPES OF OUTPUT SHAFT
STRAIGHT TYPE	
S7SA3□ ~S7SA200□	
D-CUT TYPE	
S7DA3□ ~S7DA200□	
KEY TYPE	
S7KA3□ ~S7KA200□	

▼ SPEC for output shaft of motor-(Table 4)

MODEL	TYPES OF OUTPUT SHAFT
GEAR TYPE	
S7115G□-S12 S7115G□-S24	
STRAIGHT TYPE	
S7115S□-S12 S7115S□-S24	
D-CUT TYPE	
S7115D□-S12 S7115D□-S24	

▼ KEY SPEC

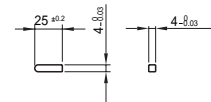

▼ WEIGHT-(Table 2)

PART	WEIGHT(kg)	
MOTOR	1.04	
DECIMAL GEAR HEAD	0.32	
GEAR HEAD	S7□A3□ ~S7□A40□	0.38
	S7□A20□ ~S7□A40□	0.47
GEAR HEAD	S7□A50□ ~S7□A200□	0.52